



MORBARK®
BUILDING EQUIPMENT THAT CREATES OPPORTUNITIES



MORBARK® DRUM CHIPPER

MODELS

30/36
40/36
50/48

HEAVY-DUTY INDUSTRIAL WHOLE TREE DRUM CHIPPERS FROM THE LEADER IN THE INDUSTRY

Creating Opportunities: Past, Present and Future

At Morbark®, we have always been there for our customers, providing new opportunities throughout our long history, and we always will be.

In 1957, Norval Morey founded the Morbark Debarker Company in Winn, Michigan. Since then, Morbark has grown from a simple blacksmith shop to a huge manufacturing complex; from two workers to hundreds of employees; and from one product to hundreds of heavy equipment designs. From our roots in the sawmill industry, we've expanded into forestry, recycling, tree care and the biomass energy markets.

We get to know you by listening to you, then improving our products based on what you say. Our equipment is durable, dependable and productive, and our name is the most trusted in the industry. When you choose Morbark, you make a commitment to excellence – and we're committed to helping you achieve success by creating new opportunities for you: unexplored revenue streams, untapped markets and better uses of by-products

With more than 50 years of ideas, invention and phenomenal growth, Morbark is recognized as a world-class manufacturing company with world-wide markets, and a reputation for designing and building robust, rugged and reliable heavy equipment.

Customer Testimonials



"I've always been frustrated by the fact that track chippers didn't have the capability to load and move at the same time. So I asked Morbark to build that in – and they did!"

Brett Kramer
Kramer's Landclearing
Linton, IN



"From all the choices we have for chippers, my Morbark is the top of the line. Productivity with tops and brush has increased by 50%. My knives need to be sharpened a lot less than on my other chippers. I have to say I have 100% confidence in my chipper."

Chris Muma
Muma Forest Products
Gladwin, MI



"The level of support we get from Morbark's dealers and the excellent parts availability from Morbark itself are outstanding – and critical to our operation. Without those two things, you risk the potential of having an expensive piece of iron sitting in the woods, costing you money instead of making you some."

Eric Dumond (left, with Mark Theriault of Theriault Tree Harvesting)
Boralex L.P.
Livermore Falls, ME

MODELS, FEATURES AND OPTIONS FOR EVEN THE MOST CHALLENGING CHIPPING JOB

Morbark® offers a full line of whole tree drum chippers in a range of sizes and in several configurations – with cab and loader (WCL) or no cab and loader (NCL), on tracks or tires, diesel or electric powered. Add to these choices a wide variety of available options, and you've got the flexibility to customize the perfect chipper for your particular needs.

All models are aggressive, highly productive, and engineered to give you the power and features you need to maximize output and enhance your profitability. In addition, they:

- Are compact for easy transportation between job sites
- Are durable and long-lasting
- Are known for high resale value

With their rigid structural frame and powerful internal-drive, single-feed-wheel infeed system, Morbark chippers are the best you can get. They can chip small, unmerchantable material, giving you access to more markets – and higher profits. These are just some of the reasons that Morbark is the largest and most respected name in chipping.

Take a look at some of the **unique** Morbark features that **help** you reduce downtime, **increase** your **profit** per job, boost resale value, and gain **peace of mind**.

[1]



[1] Infeed system

The remote-controlled infeed system features an aggressive live floor and a large top feed wheel. A high-torque drive provides positive feed of tangled brush, limbs and large-diameter logs. Its efficient, high-performance design eliminates feed-wheel slots, chains and sprockets for less exposure to debris and damage. You can create feed-wheel down-pressure when needed. And, with fewer moving parts, maintenance is easy.

[2] Feed speed

You can easily adjust feed speed to produce different chip sizes – from very small to very large – so you can cater to many markets with just one machine, multiplying your opportunities and increasing your income.

[3] Staggered knife pattern

Our proven drum design—with its staggered knife pattern, replaceable knives and knife holders, and Babbitt-style knives—allows the machine to chip smoothly, with less stress on the drum, and makes Morbark's chippers more versatile. The staggered knife pattern also helps you save money and time, because it reduces fuel consumption, increases horsepower efficiency, and extends component life.





30/36



40/36



50/48



[2] [3] [4]

[4] Knife life

Morbark machines chip evenly across the entire width of the infeed, utilizing 100% of the knives' edges. This extends knife life, saving you money and time – you may be able to change knives in as little as 15 minutes. If you hit foreign debris, you can replace just the knives and knife holders instead of the entire drum, making your chipper easier and more cost-effective to service.

[5] Morbark Integrated Control System

Morbark Integrated Control System (MICS) monitors hydraulic pressures, temperatures, clutch systems and engine efficiency to maximize performance and decrease downtime. MICS is the ultimate diagnostic tool, allowing onsite and remote troubleshooting – it's like always having a mechanic onboard to look out for and solve problems. It also tracks operational data and fuel usage.

[6] Directional flow discharge chute

You can adjust the directional flow discharge chute by remote control, allowing you to fill your vans more densely and quickly, giving you more tons per chip load.

[+] Optional CAT undercarriages

Track models feature CAT undercarriages, providing excellent ground clearance, low ground pressure, and high tracking power, so you can traverse almost any terrain to tackle tougher jobs. Morbark track models can track and chip at the same time, increasing your production and helping you make more money.





When you choose Morbark, you get more than just the best whole tree drum chipper in the industry.

You also get the benefit of more than a half-century of experience, unmatched expertise in whole tree chipping, and world-class parts, service and support. Morbark has a global network of dealers that ship, start up and support our equipment, wherever you are. If you need a replacement part, you get it when and where you need it. If you have a problem, our service team gets you up and running quickly, onsite or remotely, saving you time and money.

Create new opportunities with a Morbark Drum Chipper. Give us a call now at **800-831-0042**, or visit us at **www.morbark.com** for more information, including spec sheets and videos, and to find a dealer near you.

[+] Optional cab and loader

At Morbark, we manufacture a complete line of hydraulic knuckleboom loaders for our equipment to ensure that we can offer essential design requirements for loader speed, reach and lift capacity. The all-weather cab, with its six-way adjustable seat, increases productivity by reducing operator fatigue, and its backlit controls, clearly labeled functions, and all-digital MICS display ensure easy operation.

[+] Additional options

Customize your Morbark Drum Chipper with a variety of options: light packages, ESPAR heating system for cold-weather starts, rear stabilizers, air compressor, chip accelerator, and much more.

[+] MicroChipper option

Morbark now offers its Industrial Drum Chipper line configured to meet the tightest specifications for microchip opportunities. Options include 16- and 20-knife drums and adjustable chip sizing and forestry grates that combine to offer uniform chip production in high volumes down to a 1/4" chip size. Optional chip accelerators pack chip vans for maximum tonnages per load.





MORBARK®
BUILDING EQUIPMENT THAT CREATES OPPORTUNITIES

MORBARK® DRUM CHIPPER

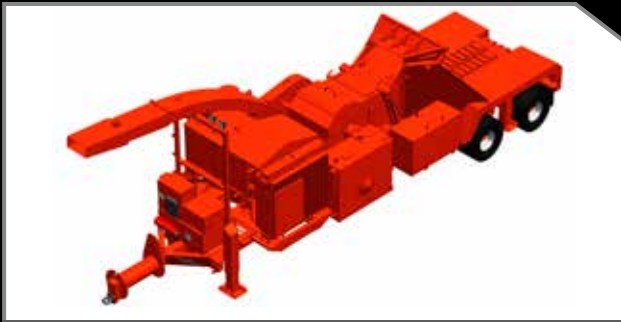

30/36

Length 32'8"
Height 11'8"
Width 8'6"
Gross weight 32,500 lbs.
Horsepower. 325 – 600 HP

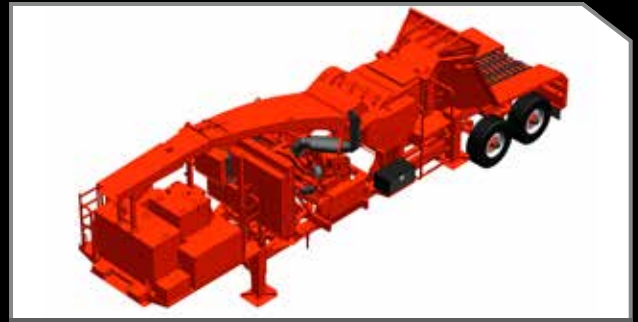

40/36

Length 37'5"
Height 12'5"
Width 8'4"
Gross weight 47,600 lbs.
Horsepower. 600 – 765 HP

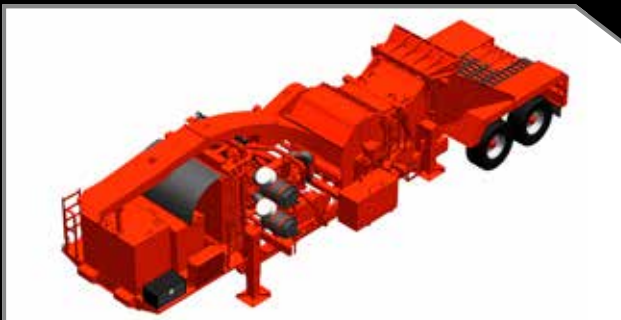

50/48

Length 40'9"
Height 12'8"
Width 10'2"
Gross weight 65,500 lbs.
Horsepower. 700 – 1,050 HP

Morbark now offers its Industrial Drum Chipper line configured to meet the tightest specifications for micro-chip opportunities. Look inside for more details on our MicroChippers.

NOTE: Equipment specifications are approximate and may change, based on options chosen or equipment updates. Find out more at www.morbark.com.